

Tripod Turnstile

User Manual

Applicable:T50000A/TS5011A/TS5022A

Version: 1.0 Date: Aug. 2017

Contents

1. Model and specification.....	2
1.1. Model number.....	2
1.2. Technical specifications.....	2
2. The installation of the product	3
2.1. Installation notes	3
2.2. Installation position of the tripod turnstile.....	3
2.3. Installation	3
2.3.1. Cables installation.....	3
2.3.2. Fix the cabinet.....	4
3. Menu operation	5
3.1. Function introduce	5
3.1.1. Button introduce.....	5
3.1.2. Menu operation.....	5
3.2. Menu introduce.....	6
4. Cable diagram	8
5. Product maintenance	9

1. Model and specification

1.1. Model number

TS5000A: Motorized Tripod Turnstile

TS5011A: Motorized Tripod Turnstile with Controller and RFID Reader

TS5022A: Motorized Tripod Turnstile with Controller and Fingerprint Reader with RFID function.

As shown below:

Access Model	NO	C3-200 with two RFID reader	inBIO260 with two FP reader
TS5000A	✓		
TS5011A		✓	
TS5022A			✓

Table 1-1

Please read this document carefully before installation and using the device.

1.2. Technical specifications

Input Voltage	AC 100V ~ 240V, 50Hz ~ 60Hz	Max Tolerance of Arms	Center: 80 kg End: 40 kg
Rated Power	60 W	Drive Mode	Motorized
Operating Environment	Indoor and Outdoor (shelter)	Arm Length (mm)	500
Operating Temperature	-28°C ~ 60°C	Net Weight (kg)	60
Operating Humidity	5% ~ 80%	Gross Weight (kg)	90
Flow Rate	30 passages / minute	Dimension(mm)	L = 1200, W = 300, H = 1010
Input Control Signal	Dry contact	Package Size (mm)	L =1330 , W =420 , H =1110

Table 1-2

TS5000A's appearance and dimensions are as shown in figure 1-1:

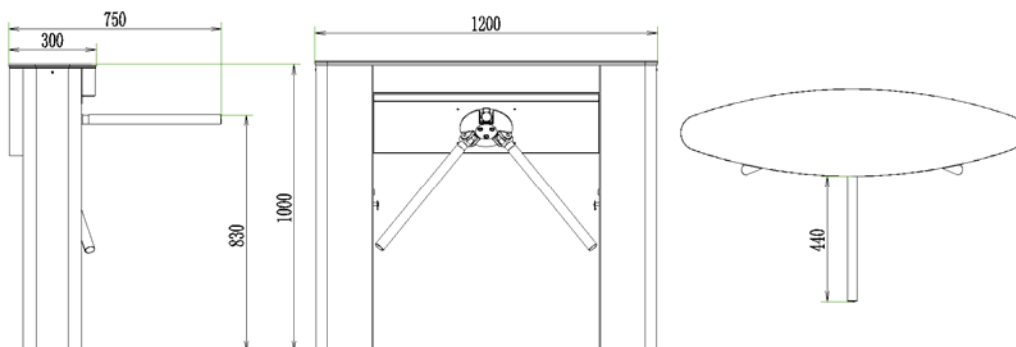

Figure 1-1

2. The installation of the product

2.1. Installation notes

- 1) It is recommended that the tripod turnstile be installed on a horizontal solid platform.
- 2) It is recommended that the tripod turnstile should not be used in corrosive environment.
- 3) Make sure the protective earth wire of the system is reliably connected to avoid personal injuries or other accidents.
- 4) After installation, check whether connection is reliable at the connecting points of the protective earth wire, at the connector assemblies and wiring points of the circuits, as well as at each movable part of the tripod turnstile. Any loose nuts, screws and other fasteners should be tightened in time to avoid tripod turnstile failures caused by long-time operations.

2.2. Installation position of the tripod turnstile

The installation position depends on the size of the tripod turnstile. If the tripod turnstile is installed near a wall, a distance of 100mm between the tripod turnstile and the wall needs to be reserved for ease of opening the top cover of the machine to perform maintenance and adjustment. The TS5000A may either form one channel, or form dual channels with two TS5000A tripod turnstiles, as shown in figure 2-1;

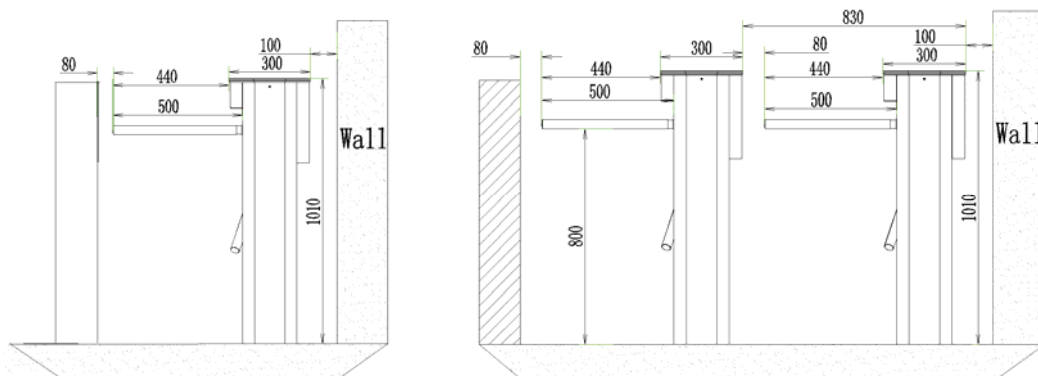

Figure 2-1 TS5000A Single channel and dual channel

2.3. Installation

2.3.1. Cables installation

For the outlets of the concealed cables, please refer to the drawing showing the mounting holes. The input voltage for this tripod turnstile is AC100-120V/200-240V. Note that the PVC conduits are buried 100mm under the ground, with the height of the exposed part not exceeding 100mm. In addition, the conduit outlet is bent back to prevent ingress of water into the conduit.

2.3.2. Fix the cabinet

Mark out the screw hole centers of the stand, and the edge of the chassis base on the ground according to the sizes as shown on the figure 2-2. Use a hammer drill to perforate M12 screw holes and then install the screws. Place the tripod turnstile according to the sizes and positions as shown in the figure before installation. Connect the cables and perform the power-on testing. If the testing is OK, tighten the screws. It is recommended that a warning line be marked out on the ground after the machine is installed, so as to prompt the pedestrian to stand behind the warning line when swiping the card. As shown in Figure 2-2:

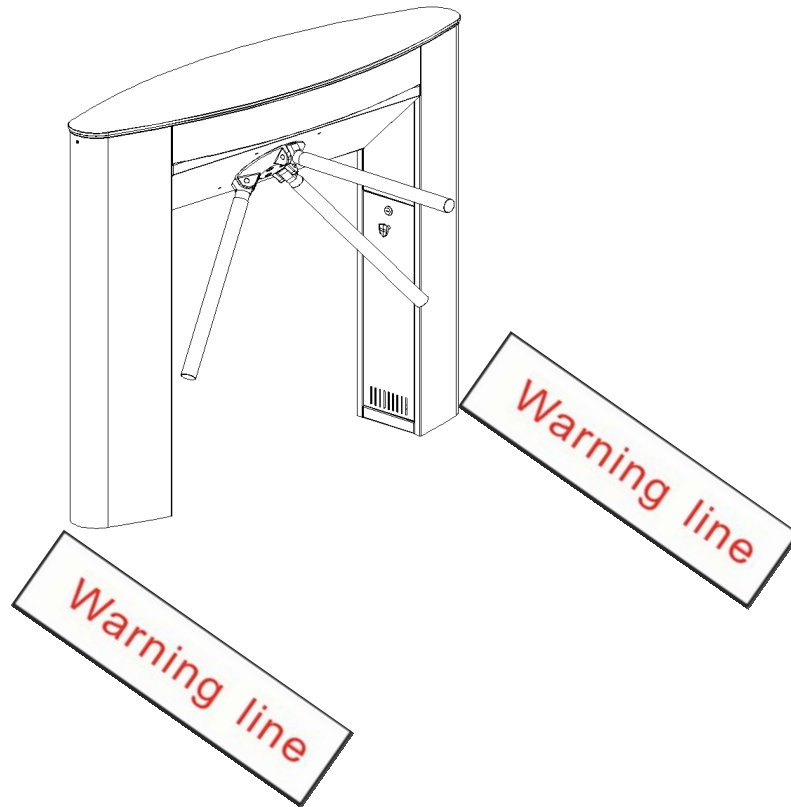

Figure 2-2

3. Menu operation

3.1. Function introduce

After turning on the switch, the LCD screen on control board will display default state, which displays currently Work Model.

3.1.1. Button introduce

There are 5 buttons "MENU, UP, DOWN, OK, CANCEL" below LCD screen, and another 2 buttons are "Right open, Left open" located on bottom right corner.

Menu: to enter menu interface

Up: to move up menu item or increase the value

Down: to move down menu item or reduce the value

OK: to enter menu setting item or confirm the current changed value

CANCEL: to return to the previous menu or to cancel the current operation.

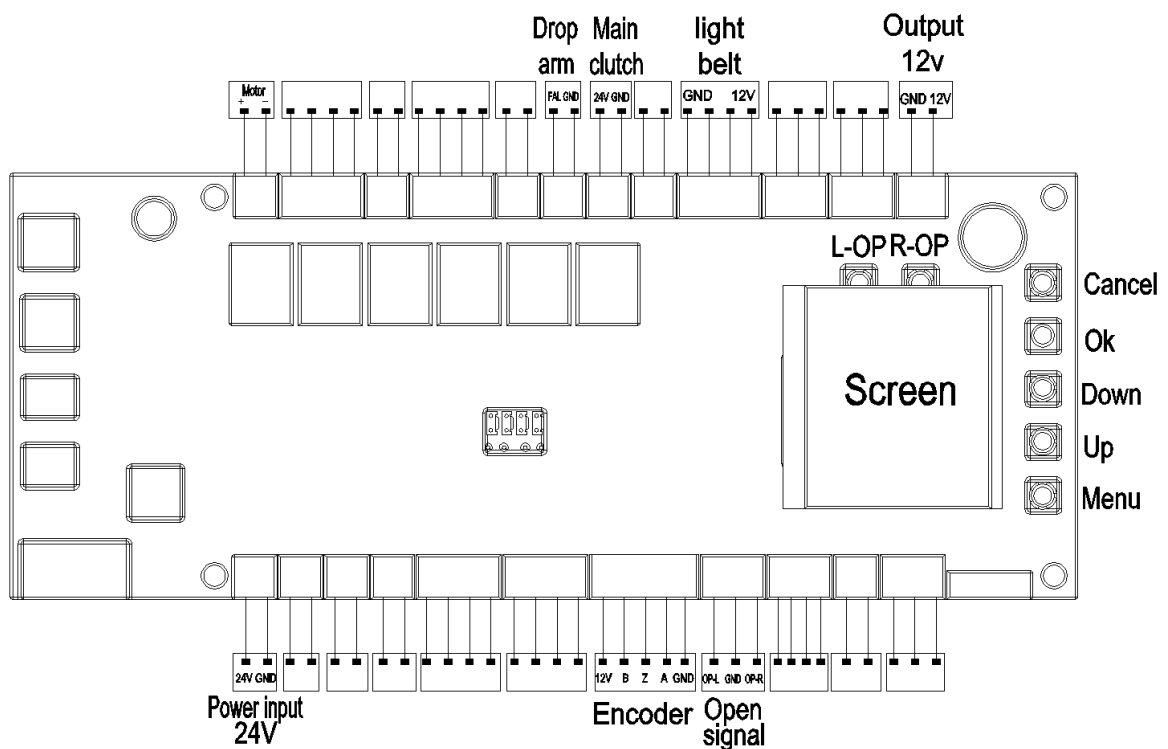

Figure 3-1

3.1.2. Menu operation

Press the MENU button, enter the password input interface, the default password is: UP, UP, DOWN, DOWN, DOWN, DOWN. If any step fails please press the CANCEL button to get back. After entering the menu press UP or DOWN to choose a menu item and then press OK to enter the interface and adjust function or value.

3.2. Menu introduce

After input correctly password then press "OK" and the menu operation interface is displayed

The menu has the following options:

1. Device type

Tripod Turnstile

2. Passage control

① → Y, N ←

② → N, Y ←

③ → N, N ←

④ → Y, Y ←

The setting for whether both sides of the machine (entry and exit) are allowed to pass. "→ Y, N ←" stand for being allowed on the right and forbidden on the left. "→ N, Y ←" stand for being forbidden on the right and allowed on the left. "→ N, N ←" stand for being forbidden on both sides. "→ Y, Y ←" stand for being allowed on both sides. The default setting is "→ Y, Y ←".

3. Direction setting

① → exit, entry ←

② → entry, exit ←

It is designed to decide which side to serve as entry. "→ exit, entry ←" means that right side is exit and left is entry. "→ entry, exit ←" means that right side is entry and left side is exit. The default setting is "→ exit, entry ←".

4. Memory function

① → Y, N ←

② → N, Y ←

③ → N, N ←

④ → Y, Y ←

With the memory function, the tripod turnstile could remember at many swipes of one card at one time and allows many people to pass so they don't have to swipe card each time. "→ Y, N ←" stand for being allowed on the right and forbidden on the left. "→ N, Y ←" stand for being forbidden on the right and allowed on the left. "→ N, N ←" stand for being forbidden on both sides. "→ Y, Y ←" stand for being allowed on both sides. The default setting is "→ N, N ←".

5. Open duration

Press the "UP" and "DOWN" button to adjust the time. Press "OK" button to save.

After the barrier is open, it will automatically close if no one passes. The default setting time is 5 seconds.

6. Turning angle

Press the UP and DOWN button to set turning angle. Press OK button to save. The turning angle can be adjusted from 1 to 30 degree. The default turning angle is 10 degree.

7. Push angle

Press the UP and DOWN button to set push angle. Press OK button to save. The push angle can be adjusted from 1 to 30 degree. The default push angle is 5 degree.

8. Clutch mode

- ① Normal open
- ② Normal Close

9. Max motor running time

Press the "UP" and "DOWN" button to adjust the time. Press "OK" button to save.

It is designed to prevent the motor idling when the control panel is break down for external detection and other reasons causing no signal. The default setting for the maximum motor running time is 3 seconds.

10. Device number

Press the "UP" and "DOWN" button to adjust the time. Press "OK" button to save.

When many machines are put together, different device number can be used to distinguish, the default number is 1.

11. Device information

The basic information of the display panel includes type, version and etc.

12. System initialization

After success of the initialization, the panel parameters will be restored to the factory setting and the counter will be test.

13. Test mode

The turnstile will open Bi-direction repeatedly. It is mainly used to test the stability and aging of control board.

4. Cable diagram

Functions of terminals at each zone:

Power: The mains voltage is changed by a transformer to 24V DC and supplied to the main panel.

Encoder: connected to the encoder and supplies power to the encoder.

Drop arm: It is mainly used for drop arm solenoid, when power outage the arm will drop.

Clutch: Connected to clutch, when someone crash on the arm, the clutch will lock the arm.

Light: Connected to light belt on the top of the cover.

Access control power supply: Supply for the access board with 12V DC output. The maximum is 4A.

Motor: It is connected to the motor and supplies power to the motor.

The wiring diagram please check the picture below:

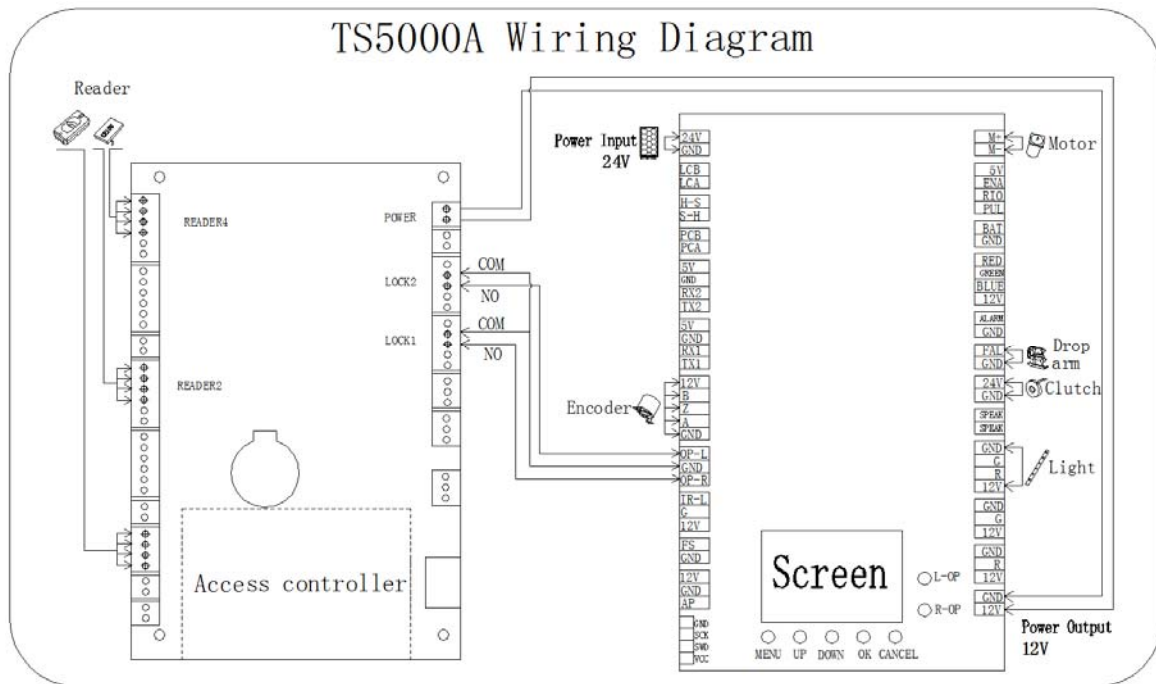

Figure 4-1

5. Product maintenance

- 1) Non-professional personnel are not allowed to open the chassis and perform tests, maintenance, or repairing on the product.
- 2) The chassis is made of semi-gloss stainless steel. The chassis surface should be cleaned frequently with a soft silk fabric. Do not use a hard article to wipe the surface to avoid scratches.
Water flushing is strictly forbidden so as to avoid water from entering the product, which may result in short circuit of the electronic control system.
- 3) Each movable part of the product should be checked on a regular basis to prevent loosening of fasteners; otherwise the barrier may fail after long-time operation.
- 4) Check the circuit connectors and wiring points on a regular basis to ensure reliable connection.
- 5) Check on a regular basis whether the system's protective earth wire is reliably connected.